

Speed Bumps

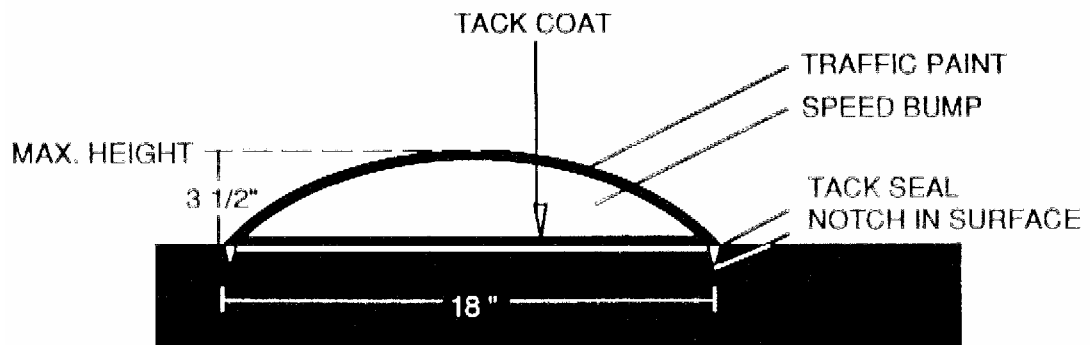

1. Lay out and mark area for placement of speed bumps.
2. Clean area of all dirt and debris.
3. Notch existing asphalt surface to alleviate speed bump displacement.
4. Tack coat area of installation using liquid asphalt.
5. Install hot mix surface asphalt to a maximum height of 3-1/2" at the apex and a width of 18".
6. Apply a seal of liquid asphalt to the adjoining edge of the installation to help prevent moisture penetration.
7. Apply heavy-duty reflective traffic paint sufficient to identify the speed bump.

